

# SONANCE

## SOUNDBAR DATA SHEET

### ADJUSTABLE WIDTH SOUNDBAR

#### TECHNICAL SPECIFICATIONS

	<b>SB46 M</b> 93086	<b>SB46 L</b> 93087
<b>SKU</b>	93086	93087
<b>UOM</b>	Each	Each
<b>Tweeter</b>	Three 1" (25mm) powder-coated aluminum dome, Ferrofluid cooled, chambered	Three 1" (25mm) powder-coated aluminum dome, Ferrofluid cooled, chambered
<b>Midrange</b>	Three 4" (102mm) Kevlar/Nomex laminated cone, rubber surround	Three 4" (102mm) Kevlar/Nomex laminated cone, rubber surround
<b>Woofer</b>	Six 4.5" (114mm) Kevlar/Nomex laminated cone, rubber surround	Six 4.5" (114mm) Kevlar/Nomex laminated cone, rubber surround
<b>Frequency Response</b>	90Hz-20Hz +/-3dB	90Hz-20Hz +/-3dB
<b>Impedance</b>	8 Ohms nominal; 6 Ohms minimum	8 Ohms nominal; 6 Ohms minimum
<b>Power Handling</b>	50 Watts minimum; 150 Watts maximum	50 Watts minimum; 150 Watts maximum
<b>Sensitivity</b>	88dB SPL (2.83V/1 meter)	88dB SPL (2.83V/1 meter)
<b>Grille Material</b>	Perforated steel	Perforated steel
<b>Dimensions (HxD)</b>	5.281" x 2.5625" (134mm x 65mm)	5.281" x 2.5625" (134mm x 65mm)
<b>Adjustable Width (W)</b>	43.875" to 59.625" (1114mm to 1514mm)	61.5" to 77.3125" (1562mm to 1964mm)
<b>Display Diagonal Size Range</b>	50" - 65" (127cm - 165cm)	70" - 80" (178cm - 203cm)
<b>Product Weight</b>	21 lbs (9.5 kg)	26 lbs (11.8 kg)
<b>Shipping Weight</b>	30 lbs (13.6 kg)	35 lbs (15.9 kg)

#### DIMENSIONAL DRAWINGS

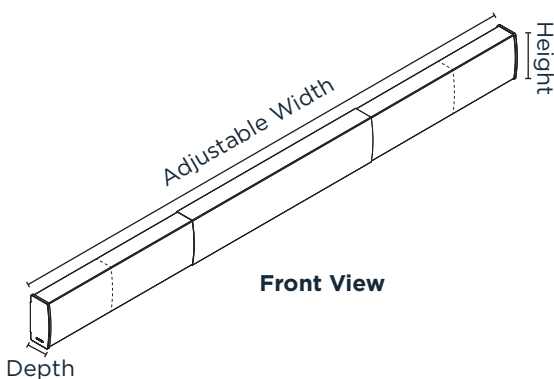

#### ASSOCIATED PRODUCTS

VP46R SST/SUR	93023
VP66R SST/SUR	93025
VPSUB	93352
DSP 8-130 MKII Amplifier	93331
i12 Cabinet Subwoofer	93358
i10 Cabinet Subwoofer	93357
i8 Cabinet Subwoofer	93356

**LIMITED FIVE (5) YEAR WARRANTY** Sonance warrants to the first end-user purchaser that this Sonance-brand product ("Product"), when purchased from an authorized Sonance Dealer/Distributor, will be free from defective workmanship and materials for the period stated above. Sonance will at its option and expense during the warranty period, either repair the defect or replace the Product with a new or remanufactured Product or a reasonable equivalent. For more details please refer to the product manual.

©2021 Sonance. All rights reserved. Sonance is a registered trademarks of Dana Innovations. Due to continuous product improvement, all features and specifications are subject to change without notice. For the latest Sonance product specification information visit our website at [www.sonance.com](http://www.sonance.com).

SONANCE • 991 Calle Amanecer • San Clemente, CA 92673 USA • Phone: (949) 492-7777 • Fax: (949) 361-5151 • Technical Support: (949) 492-7777 • [www.sonance.com](http://www.sonance.com) 08.08.2021